

CODIGO	MATERIAL	E	F. INS. [Kg]	F. 10° EXT. [Kg]	OBSERVACIONES
11020xx388 (20.388)	LATON	0.45	≤ 8.0	2.0 / 7.0	
② 11020xx398 (20.398)	AC. INOXIDABLE	0.40	≤ 8.0	2.0 / 7.0	

**ESTE PLANO ESTA SUJETO A MODIFICACIONES SIN PREVIO AVISO**

⑤ ④

**COPIA NO CONTROLADA**

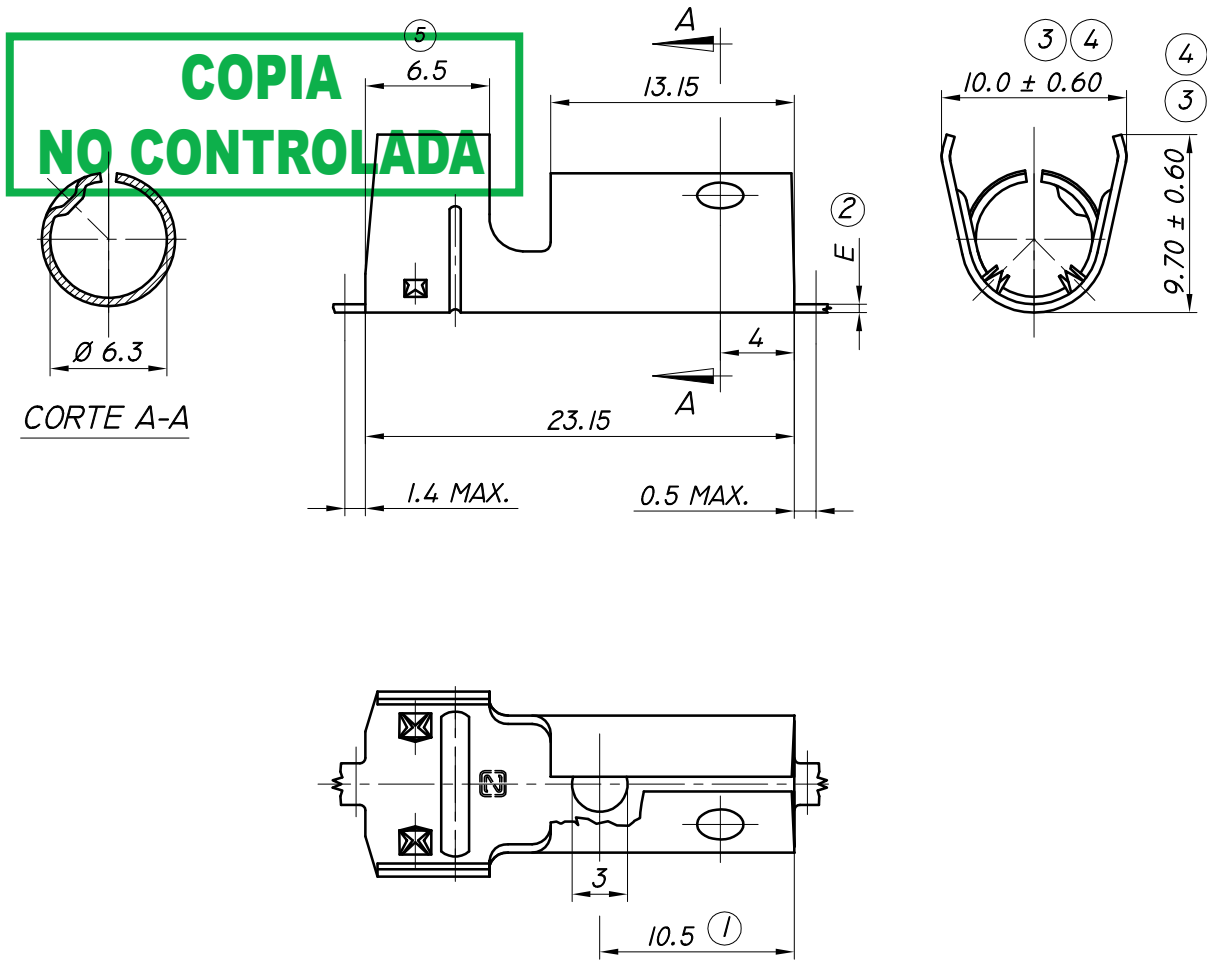

03.03.23	5	COTA 6.5 ERA 6.7.	L.L.		
12.04.10	4	COTA 10.0 ERA 10.2 Y 9.70 ERA 10.0.	L.L.	O.A.C.	GARCIA
09.06.05	3	TOLERANCIA COTA 10.2 ERA ± 0.3 Y TOL. COTA 10 ERA ± 0.2	L.L.	O.A.C.	GARCIA
04.03.04	2	SE AGREGA PIEZA 20398.	P.S.	O.A.C.	GARCIA
16.04.03	1	ERA 13.15	P.S.	O.A.C.	GARCIA
FECHA	Nº	MODIFICACIONES	DIBUJO	REVISO	APROBO

**Z** INDUSTRIAS ZETA S.R.L.

TOLERANCIA NO ACOTADA:  
LINEAL: ±0.15  
ANGULAR: ± 1° 30'

MATERIAL: VER TABLA	ESCALA: 2.5:1	DIBUJO	REVISO	APROBO
CODIGO MAS: /E = TERMINACION ESTAÑADA /N = TERMINACION NIQUELADA /P = TERMINACION PLATEADA /S = PIEZA SUELTA	HOJA: 2 DE 2	P.S.	O.A.C.	GARCIA
		24.03.03	24.03.03	24.03.03
DENOMINACION: TERMINAL CONTACTO BUJIA			PLANO PARA CLIENTE Nº:	20.000